

ALUMA-FORM, INC.



ALUMA-FORM®

Aluma-Form, Inc.

3625 Old Getwell Road
Memphis, TN 38118
P.O. Box 18555 • Memphis, TN 38181-0555
Phone 901-362-0100
Fax 901-794-9515

www.alumaform.com

ARMS AND BRACES

ALUMA-FORM, INC.

CATALOG

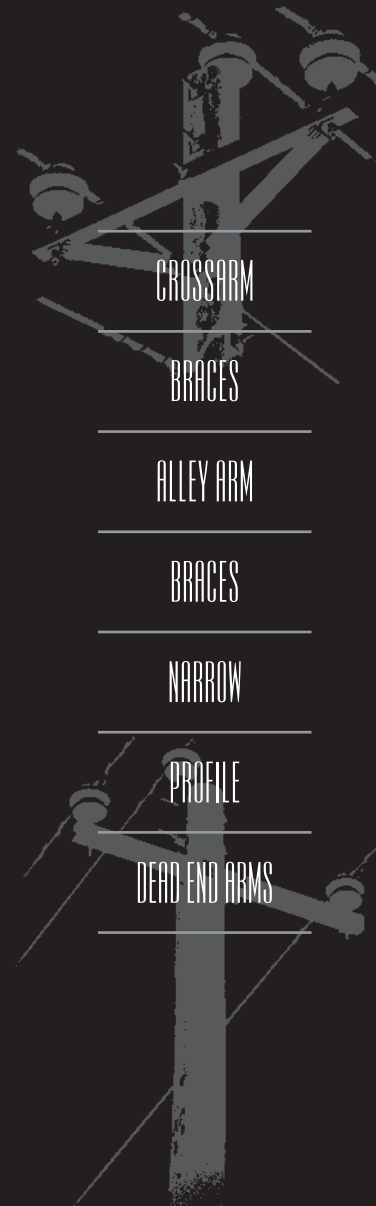

ALUMA-FORM®

NO-BOLT CROSSARM BRACES ALUMA-FORM®

Unique extruded aluminum end fitting delivers more strength. Less weight, eliminates static-producing bolts and looks better on the pole!

Aluma-Form braces feature patented design* end fittings of extruded aluminum 6061-T6 alloy that eliminates the need for bolted fittings. The greater shear and friction area gripped by the Aluma-Form end fitting allows the use of smaller wood members thereby reducing weight and producing a more eye pleasing brace that is stronger than bolted fittings.

Under-Arm Braces



Model "A"



Reversible Model "RA"

High Density APITONG BRACES Cross Section 1-3/4" x 1-3/4" Hole Size 9/16" at arm 11/16" at pole	Dimensions		
	Catalog #	Span	Drop
	A4814 or RA4814	48"	14"
	A4818 or RA4818	48"	18"
	A4824 or RA4824	48"	24"
	A6018 or RA6018	60"	18"
	A6030 or RA6030	60"	30"
	A7222 or RA7222	72"	22"
	A7236 or RA7236	72"	36"

Braces are sold in pairs

Slim Line™ Crossarm Braces



Economical, strong/high density 1 1/4" Square Apitong Wood, Patented* 6061-T6 Aluminum end fittings

- No-bolt fittings reduces static
- Reversible
- Light weight, looks better on pole

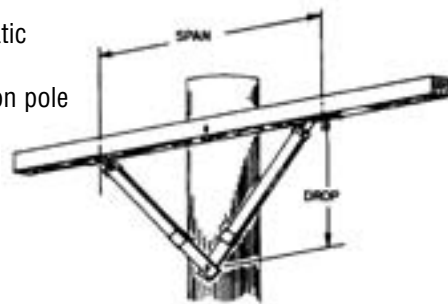

Slim Line™ Reversible Braces

Apitong-Cross Section 1 1/4" x 1 1/4"
Hole size 9/16" at Arm-11/16" at pole.

Catalog #	Dimensions	
	Span	Drop
AF-4814	48"	14"
AF-4818	48"	18"
AF-4824	48"	24"
AF-6018	60"	18"
AF-6030	60"	30"
AF-7222	72"	22"

*U.S. Patent No. 4596105

Apitong wood has been proven to be reliable for over 60 years.

ALUMA-FORM® FLAT APITONG BRACES



Cross Section 13/16" x 1-3/4" Hole Size 7/16" at arm 9/16" at pole	Catalog #	Dimensions	
	AF626	Span	Drop
		38"	18"

U.S. Patent No. 4596105

Alley Arm Braces

RAAB

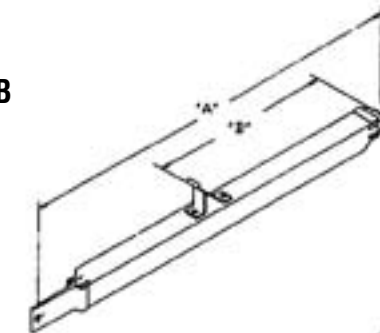

AAB

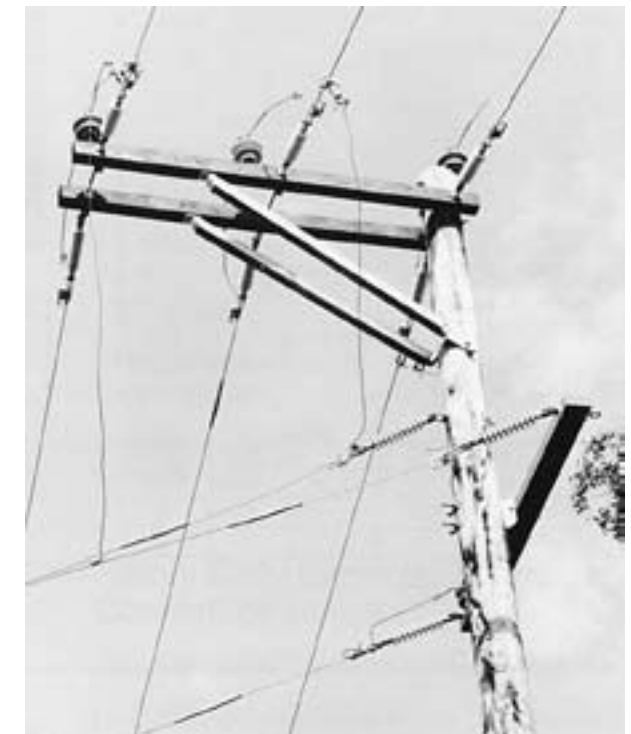
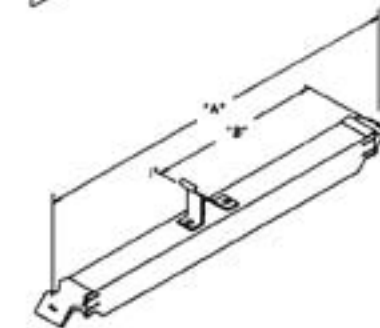

Come complete with lineman's step. For applications where step is NOT required, add suffix-L/S to catalog number. Alley Arm braces are supplied in the traditional style (AAB series) or Reversible style (RAAB series). Alley Arm Braces are made of high strength 2 11/16" x 2 11/16" 'apitong' wood and "boltless" aluminum end fittings. End fittings are normally supplied containing a 11/16" dia. mounting hole.

Catalog #	Dim. A	Dim. B	Approx. Weight
AAB or RAAB-60	60"	20 3/4"	14 lbs.
AAB or RAAB-76	76"	20 3/4"	17 lbs.
AAB or RAAB-84	84"	20 3/4"	19 lbs.

Apitong wood has been proven to be reliable for over 60 years.

Maintain favorable B.I.L. with our complete line of narrow profile wood conductor supports.

- Strong, durable Apitong wood
- 6061-T6 aluminum
- Neat, narrow profile appearance

Aluma-Form® also has a complete line of Apitong Alley Arms and other insulated equipment mounts, all backed by Aluma-Form's high standards of quality and service.

Aluma-Form Conductor Support

These low profile, structurally integrated Apitong units are fully assembled. They include pins, braces and horizontal support member. Optional '2T' Take-off bars are available for dead-ending primary service drops. Also, these units are pre-drilled for double dead-end construction using 5/8" dia. hardware.

All assemblies are supplied with 1" dia. lead thread pins. Please contact us for availability should larger pins be required.

Our standard package is (20) units per pallet. When ordering less than standard package quantities, a repacking charge may occur.

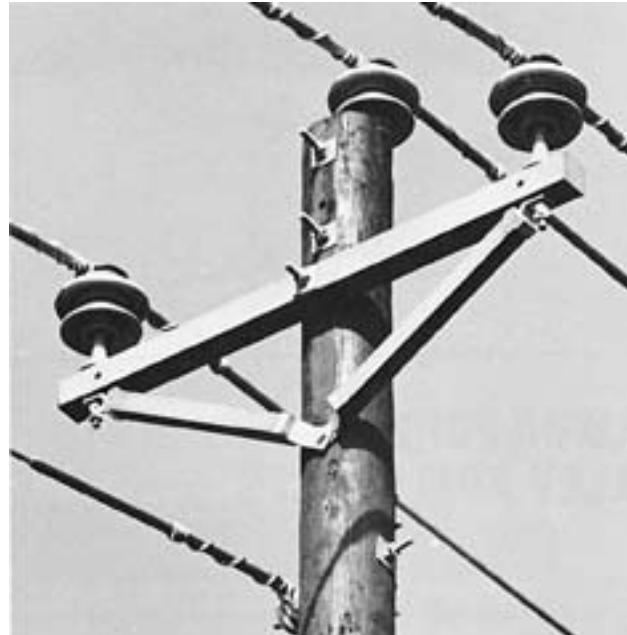

Catalog #	Part #	Weight	Description
XA-3812-2T	54501	22 lbs.	Conductor support assembly with 38" pin spacing and take-off bars.
XA-3812	54502	21.5 lbs.	Same as above, less take-off bars.
XA-4214-2T	54503	26.5 lbs.	Conductor support assembly with 42" pin spacing and take-off bars.
XA-4214	54504	26 lbs.	Same as above, less take-off bars.
2T	01155	0.3 lbs.	Take-off bar for retrofit of existing units.

Engineering Data Dimensions

Catalog #	'A'	'B'	'C'	'D'	'E'	'F'
XA-3812	38"	36"	18"	12.75"	3"	4"
XA-3812-2T	38"	36"	18"	12.75"	3"	4"
XA-4214	42"	40"	20"	14"	3"	4"
XA-4214-2T	42"	40"	20"	14"	3"	4"

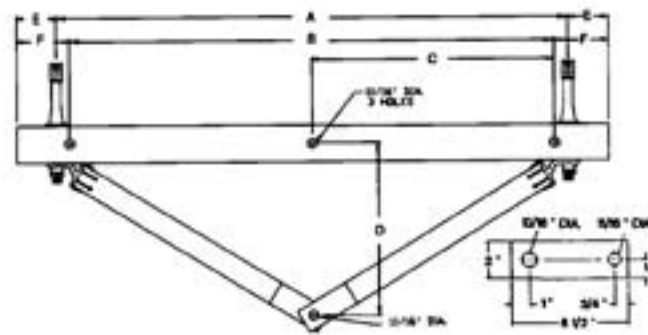

Narrow Profile Conductor Support Three Position Conductor Support Assembly

These narrow profile, structurally integrated units are fully assembled. They include crossarm pins, captive pole top pin, & wood arm fixed to an extruded aluminum pole gain. Optional '2T' take-off bars are available for dead-ending primary service drops.

- Assemblies are furnished with 1" dia. lead thread crossarm pins. 1-3/8" thread diameter pins may be supplied; please contact us for availability.
- Other phase spacings can be provided. Please contact us for a custom proposal meeting your specifications.

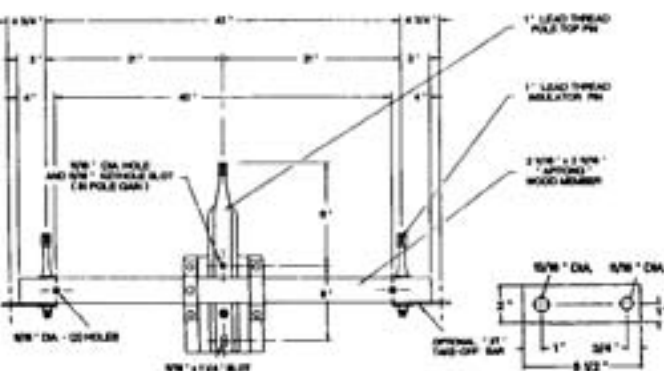

Catalog #	Product #	Weight	Description
NPS-3-42	54523	28 lbs.	42" assembly less '2T' take-offs
NPS-3-42-2T	54524	28.5 lbs.	42" assembly less '2T' take-offs

Narrow Profile Conductor Support Two Position Conductor Support Assembly

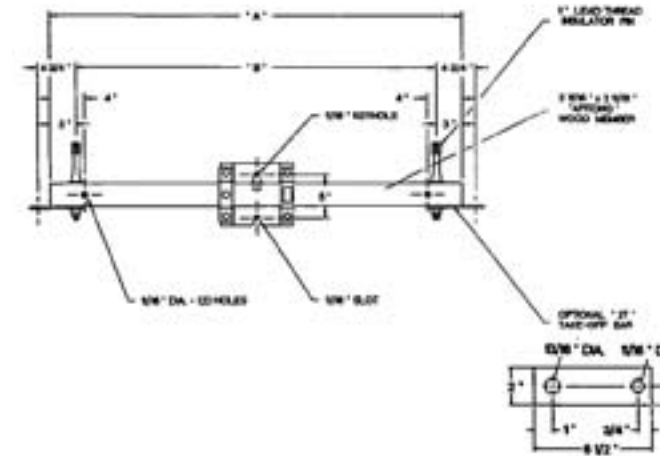

Catalog #	Product #	Dim. A	Dim. B	Weight	Description
NPS-38	54518	44"	38"	16 lbs.	36" pin center ass'y less '2T' take-offs
NPS-42	54519	48"	42"	17 lbs.	42" pin center ass'y less '2T' take-offs

These narrow profile, structurally integrated units are fully assembled. They include crossarm pins & wood arm fixed to an extruded aluminum pole gain. Optional '2T' take-off bars are available for dead-ending primary service drops.



- These assemblies are furnished with 1" dia. lead thread crossarm pins. Should 1-3/8" diameter pins be required, please contact us for availability.
- Other pin spacings can be provided in certain cases. Please contact us for a custom quotation to your specifications.

Heavy Duty Narrow Profile Conductor Support Two Position Conductor Support Assembly

These Heavy Duty Narrow Profile Supports are shipped FULLY assembled, with the wood arm fixed to an extruded aluminum pole gain. These units are predrilled for use with standard crossarm pins (NOT included) Optional "take-off" bars are available for dead ending primary service drops, or mounting other electrical equipment. Other phase spacings can be provided. Please contact us for a custom proposal addressing your specific needs.

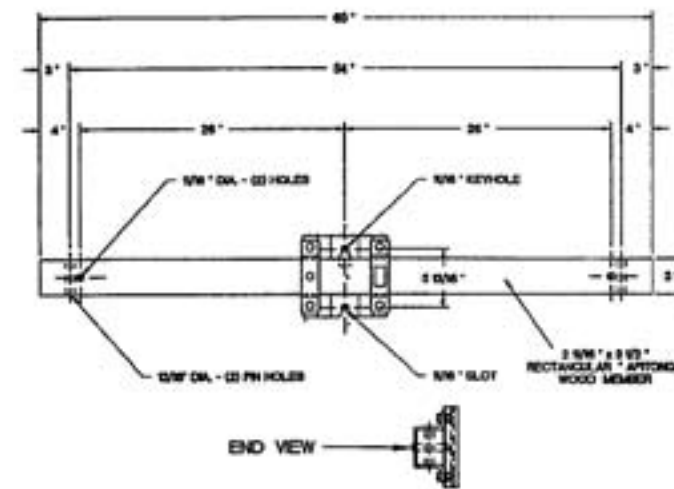

Catalog #	Product #	Weight	Description
HD-NPS-54	54525	30 lbs.	Heavy Duty 54" Conductor Support Assembly

Two Position Dead End Arm Assembly

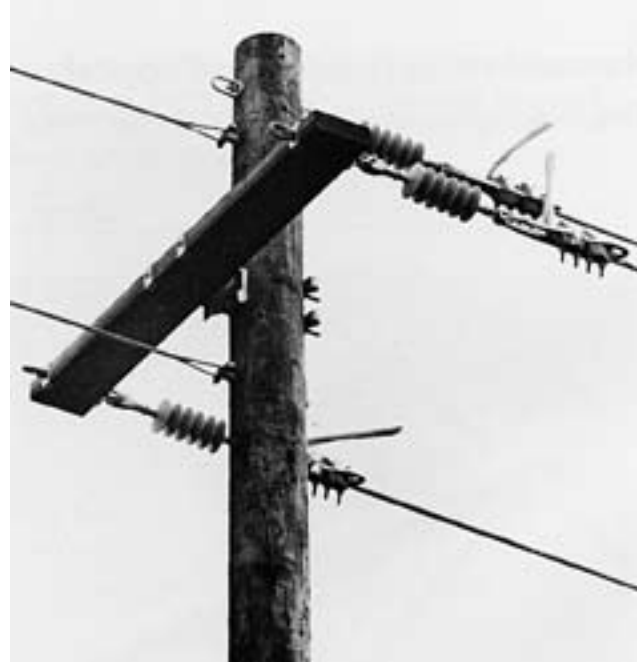
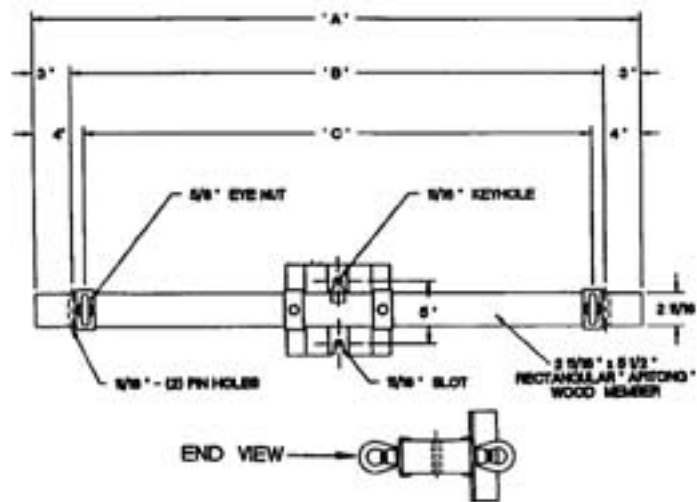

Catalog #	Product #	Dim. A	Dim. B	Dim. C	Description
DEA-36-EB	54312	44"	38"	36"	36" dead-end arm assembly
DEA-48-EB	54318	56"	50"	48"	48" dead-end arm assembly
DEA-60-EB	54319	68"	62"	60"	60" dead-end arm assembly

These Dead End Arm Supports are fully assembled. For convenience they are predrilled for dead-end hardware and for crossarm pins.

- Our standard package is (20) units per pallet. When ordering less than std. package quantities, a repacking charge may occur.

8 Foot Dead End Assembly

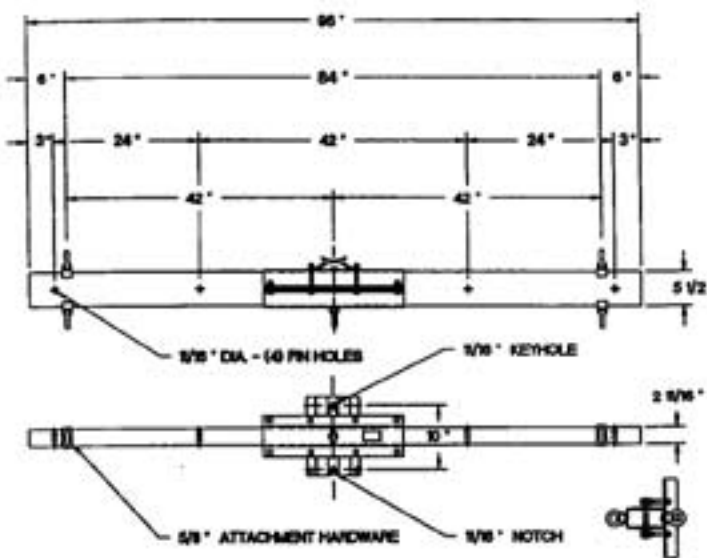

This unique Dead End Assembly design features 'apitong' wood integrated with our extruded aluminum hat section and pole gain. This produces a high strength, light weight Dead End Assembly with a 'slim line' appearance. NO bracing required. These units ship FULLY assembled including dead end attachment hardware. They are ready to install. Other sizes and styles are available. Please contact us for information.

Catalog #	Product #	Weight	Description
DEA-84-EB	54315	65 lbs.	8 ft. 'Apitong' Dead End Arm Assembly

Accessory Items

HD-2T

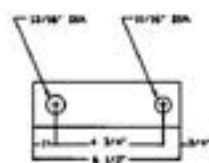

HD-3T

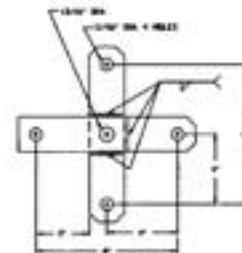

Apitong wood has been proven to be reliable for over 60 years.

- High performance, light weight
- Entirely factory assembled
- NO braces required
- Predrilled for standard pins
- Installs with ONLY two thru-bolts
- NO special hardware or tools needed

Model HD-DEA-86-EB-REA

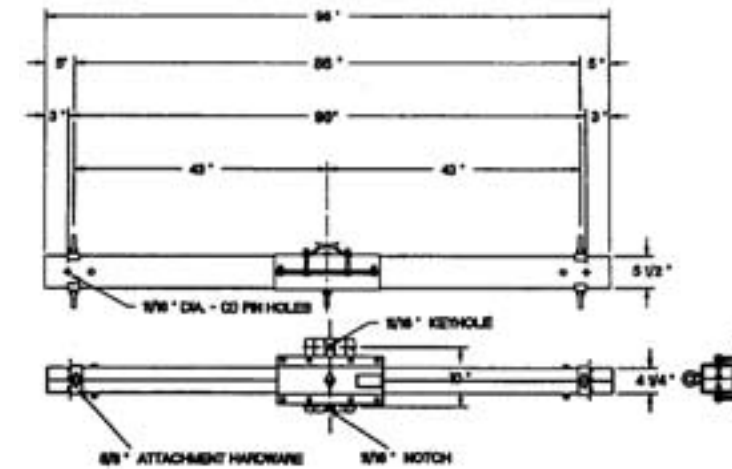

REA item (gj) accepted 8 foot dead end crossarm assembly. REA accepted 10' dead end crossarm assemblies also available.

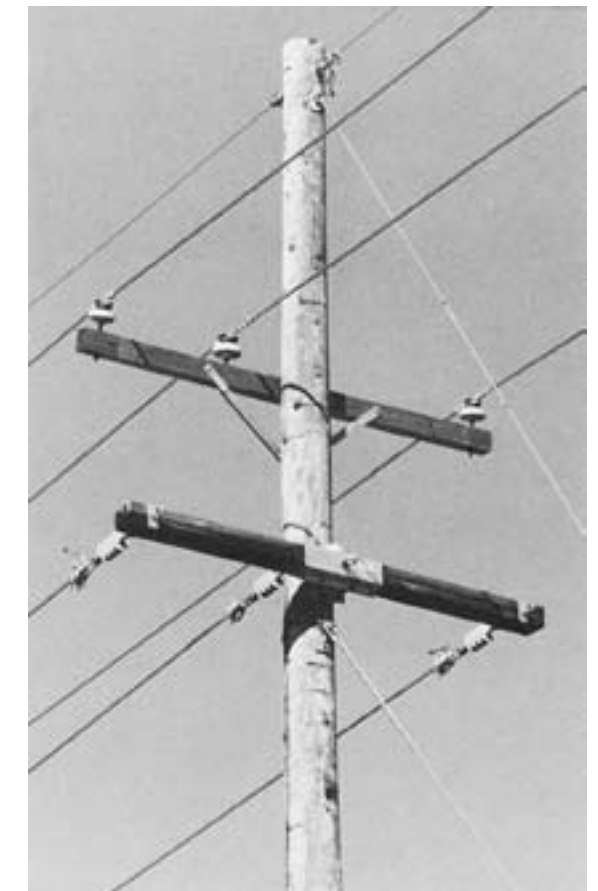

Apitong Dead End Assembly Product Selection Chart

Aluma-Form offers a full line of integrated Dead End Arm assemblies in popular lengths, sizes and strengths; plus, various conductor spacings and three wire or four wire designs. Available accessories include our "HD-2T" and HD-3T Take-Off" bars for conductor attachment or electrical equipment mounting, and single or double down guy attachments. Our full line of high performance assemblies meet most distribution line construction

needs. You will find, below, a chart to assist you in selecting the proper product style to meet your particular application. Match desired ultimate strength per phase with needed phase spacing, to find the proper product series. Then, please contact us or your local sales representative for existing product selection, further assistance or for a specific proposal to your requirements.

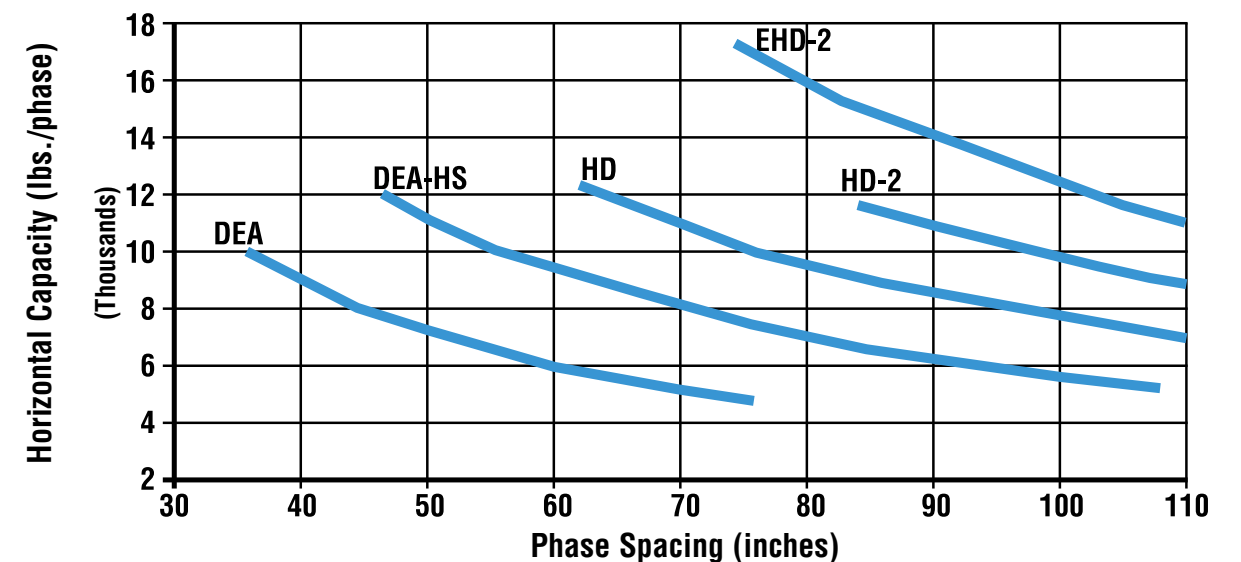

Apitong wood has been proven to be reliable for over 60 years.